

Project	IEEE 802.16e Broadband Wireless Access Working Group < http://ieee802.org/16 >
Title	Periodic Ranging and Keep-Alive Check in Sleep Mode
Date Submitted	2006-09-22, Version: 1.0
Source(s)	Yeongmoon Son Samsung Electronics Ltd. ym1004.son@samsung.com
Re:	Call for Maintenance Change Requests on IEEE Std 802.16
Abstract	This document suggests changes in TGe Draft Document IEEE 802.16e-2005 to introduce CDMA code-based Periodic Ranging to Sleep Mode and clarify Keep-Alive check in Sleep Mode
Purpose	Adopt into the current Maint TG draft
Notice	This document has been prepared to assist IEEE 802.16. It is offered as a basis for discussion and is not binding on the contributing individual(s) or organization(s). The material in this document is subject to change in form and content after further study. The contributor(s) reserve(s) the right to add, amend or withdraw material contained herein.
Release	The contributor grants a free, irrevocable license to the IEEE to incorporate material contained in this contribution, and any modifications thereof, in the creation of an IEEE Standards publication; to copyright in the IEEE's name any IEEE Standards publication even though it may include portions of this contribution; and at the IEEE's sole discretion to permit others to reproduce in whole or in part the resulting IEEE Standards publication. The contributor also acknowledges and accepts that this contribution may be made public by IEEE 802.16.
Patent Policy and Procedures	The contributor is familiar with the IEEE 802.16 Patent Policy and Procedures < http://ieee802.org/16/ipr/patents/policy.html >, including the statement "IEEE standards may include the known use of patent(s), including patent applications, provided the IEEE receives assurance from the patent holder or applicant with respect to patents essential for compliance with both mandatory and optional portions of the standard." Early disclosure to the Working Group of patent information that might be relevant to the standard is essential to reduce the possibility for delays in the development process and increase the likelihood that the draft publication will be approved for publication. Please notify the Chair < mailto:chair@wirelessman.org > as early as possible, in written or electronic form, if patented technology (or technology under patent application) might be incorporated into a draft standard being developed within the IEEE 802.16 Working Group. The Chair will disclose this notification via the IEEE 802.16 web site < http://ieee802.org/16/ipr/patents/notices >.

Periodic Ranging and Keep-Alive Check in Sleep Mode

Yeongmoon Son^{*}, Shahar Itzik^{**}, Yerang Hur^{***}, Paul Bazzaz[#],

Kiseon Ryu^{##}, Anders Lamm^{###}

Samsung^{*}, Intel^{**}, Posdata^{***}, SEQUANS[#], LGE^{##}, Ericsson^{###}

1. Problem Statement

In IEEE Std 802.16e-2005, it is unclear what method to use for periodic ranging and automatic adjustments in sleep mode, since the chapter 6.3.10.2 has the intention that message based periodic ranging is used for other PHYs (i.e. SC, SCa and OFDM) rather than OFDMA. In the chapter 6.3.10.3, CDMA based ranging for OFDMA is described. However in the chapter 6.3.21.5, Periodic ranging in sleep mode, which is currently described, is Message-based which is not the intention for OFDMA periodic ranging.

Moreover for mobile systems there is a need for BS to be able to perform a keep-alive mechanism in order to supervise the MS in the network as well as perform regular measurements to be able to adjust power, frequency and timing for improved overall system performance. Using CDMA based ranging for purpose of regularly checking for adjustments has two drawbacks. Since it is anonymous, the BS cannot use it for keep-alive purpose and also it leads to waste of air interface resources, since each CDMA-based rng-req will need a rng-rsp message even if no adjustments are needed.

2. Proposed Remedy

2.1 Clarifications of periodic ranging for OFDMA versus other PHY.

In this remedy we conclude that periodic ranging for OFDMA is CDMA-based and thus shall be controlled by MS, triggered by MS timer T4 as described in 6.3.10.3.2. Whenever T4 expires in normal mode MS shall perform CDMA-based periodic ranging and in sleep mode MS may perform CDMA ranging during an availability interval or it may skip the periodic ranging depending on MS vendor implementation. If necessary MS may anonymously extend an availability interval in order to perform CDMA ranging.

2.2 Clarifications of BS controlled keep-alive signalling

Keep-alive signaling is an optional feature that may be implemented by BS to improve overall network performance.

Keep-Alive signaling can also be used for measurements of power, frequency and timing offset and if necessary adjustments to MS can be done by RNG-RSP. In order to avoid unnecessary use of CDMA code-based ranging we propose that MS informs BS of value of timer T4 in REG-REQ message during Network Entry or Re-Entry so that BS can set internal keep-alive timer according to vendor specific algorithms.

Implementation of keep-alive signaling is BS vendor specific, but MS must support both signaling in sleep mode. We propose 2 alternative methods to perform keep-alive signaling that need to be supported by MS.

1. BS allocating a single separate availability interval defined by next_periodic ranging_TLV during MOB_SLP-RSP and RNG-RSP. Next_Periodic_Ranging_TLV may overlap with an availability interval.
2. BS using existing availability intervals according to current sleep mode definitions for unsolicited UL data grants.

What method to use is decided by BS by optionally including next-periodic TLV in MOB_SLP-RSP and RNG-RSP.

These two keep-alive schemes are illustrated below.

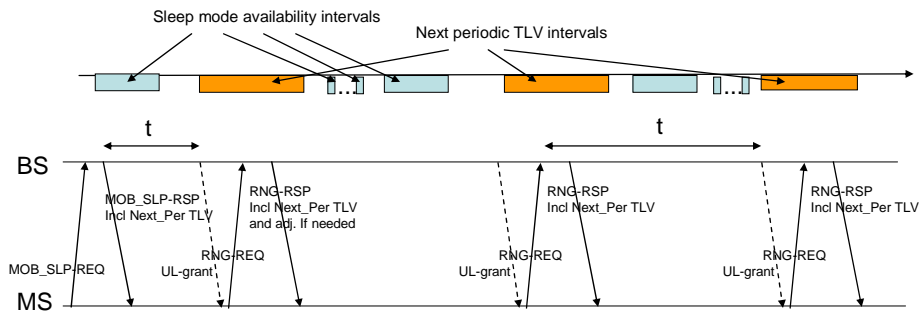

Fig 1. Sleep mode, Keep-Alive Check with Next-Periodic Ranging TLV

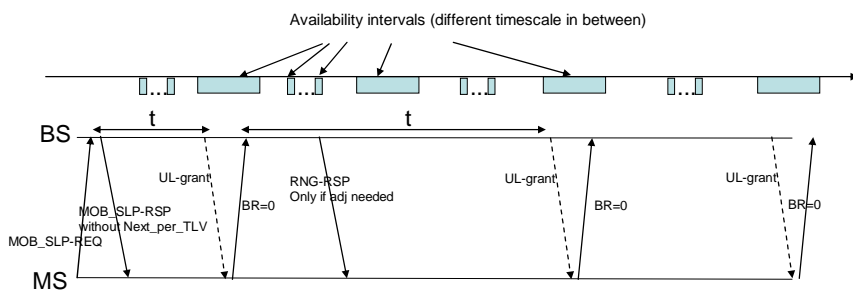

Fig 2. Sleep mode, keep alive with unsolicited UL data grants in availability intervals (i.e. Sleep Mode, Keep-Alive Check without Next Periodic Ranging TLV)

2.3 Description of methods

2.3.1 Keep-Alive check using next-periodic_ranging_TLV

Keep alive using next-periodic TLV can be applicable for keep-alive check with long duration.

BS allocates UL transmission opportunity (i.e. UL unicast burst) to MS in the frame specified by Next Periodic Ranging TLV encoding. Also, an MS shall wake and decode consequent UL-MAP messages waiting for a UL unicast burst in that frame. When the MS receives UL unicast burst, it shall transmit a RNG-REQ message on UL unicast burst to BS. After BS receives a RNG-REQ message, BS shall determine whether MS requires an additional adjustment or not, thereafter send a RNG-RSP message with appropriate ranging status (i.e. Success, Continue, or Abort). In case of Ranging Status = Success and Continue, BS shall include Next Periodic Ranging TLV encoding in the RNG-RSP message so that the MS can know when to wake up for next keep-alive event as keep-alive signals during sleep mode. This mechanism is similar to Message-based Periodic Ranging in sleep mode for other PHYs (i.e. SC, SCa and OFDM)

The above scenario is a normal operation for periodic ranging or keep-alive check in sleep mode. But, let's think about an unexpected abnormal periodic ranging operation in sleep mode, as follows.

- BS allocates UL unicast burst to the MS in the frame specified by Next Periodic Ranging TLV. But, MS may not recognize or decode the allocation of the UL unicast burst due to bad channel quality and so on. In this case, BS can't receive a RNG-REQ message from the MS on UL unicast burst allocated by it.
- MS recognizes UL unicast burst allocated by allocates, and transmits a RNG-REQ message on the UL unicast burst. But, BS may not recognize the transmission of RNG-REQ message on the UL unicast burst.
- BS can send a RNG-RSP message with ranging status = Abort to MS in sleep mode.

When the above abnormal operation continues after the frame specified by Next Periodic Ranging TLV encoding, what do BS and MS have to do? Actually, there is no explicit procedure about the above abnormal periodic operation in periodic ranging during sleep mode. Therefore, we propose the two timers to solve the above problem and apply some mechanism for keep-alive and periodic ranging during sleep mode.

For the purpose to resolve the above problems and apply some mechanism for keep-alive and periodic ranging during sleep mode, we propose two timers as follows :

- T48 : maximum duration that MS has to wait for UL Unicast Bursts allocated by BS after periodic ranging operation starts in the frame specified by Next Periodic Ranging TLV encoding.
- T49 : maximum duration that BS has to wait for RNG-REQ messages sent by MS after periodic ranging operation starts in the frame specified by Next Periodic Ranging TLV encoding

For Keep-Alive check for an MS in sleep mode, BS may include Next Periodic Ranging TLV encoding in MOB_SLP-RSP or RNG-RSP message. In this case, BS shall allocate an UL transmission opportunity for RNG-REQ message to an MS in the frame specified by Next Periodic Ranging TLV encoding. And, MS shall transmit a RNG-REQ message on the UL burst allocated by the BS. When BS receives the first RNG-REQ message on UL burst allocated by the BS, BS shall send unconditionally a RNG-RSP with ranging status = Success including Next Periodic Ranging TLV encoding so that MS can know when to perform keep-alive operation in future. But, if the BS wants to perform additional adjustment for the MS, BS may send the RNG-RSP message with ranging status = Continue including Next_Periodic_Ranging TLV encoding so that the

MS can know when to perform keep-alive operation in future. In this case, MS shall remain awake and perform CDMA code-based Periodic Ranging operation(refer to 6.3.10.3.2) until BS sends the RNG-RSP message with ranging status = Success. MS can enter sleep mode again till the frame indicated by the Next_Periodic_Ranging_TLV encoding, if possible.

In the frame specified by Next Periodic Ranging TLV, when BS allocates a UL transmission opportunity to an MS, BS starts a timer T49 at the same time and wait to receive a first RNG-REQ message from the MS on the UL transmission opportunity. When BS receives the first RNG-REQ message from the MS on the UL burst, BS shall unconditionally terminate T49 timer. If BS doesn't receive a RNG-REQ message from MS on the UL burst for the MS, it shall continue to allocate a UL unicast burst to the MS as long as the T49 runs. But, if the T49 expires, BS shall regard the MS as being MAC-Initialized. On the other hand, in the frame specified by Next Periodic Ranging TLV, MS shall wake up and try to recognize an allocation of a UL unicast burst allocated by BS. MS shall start a timer T48 at the same time. MS shall reset T48 whenever it receives its own UL burst without RNG-RSP message for the MS. And, MS shall terminate T48 when it receives a RNG-RSP message. MS shall maintain awake so as to receive a RNG-RSP message from BS as long as the T48 runs. If T48 timer expires, MS may perform Network Entry.

When the Keep-Alive check operation between MS and BS successfully processes, the BS shall inform the MS of the frame number in which the next Keep-Alive check operation is expected to start. For that, BS shall append a Next Periodic Ranging TLV encoding to the RNG-RSP message. If MS receives a RNG-RSP message with ranging status = Success including Next_Periodic Ranging TLV encoding, MS shall recognize the frame to wake up for next Keep-Alive check. If MS receives a RNG-RSP message with ranging status = Continue including Next_Periodic Ranging TLV encoding, MS shall perform CDMA code-based Periodic Ranging together with saving of the frame to wake up for next Keep-Alive check.

Figure 3 shows the example of the proposed operation of keep alive signaling during intervals defined by next_periodic TLV including timers for abnormal operation

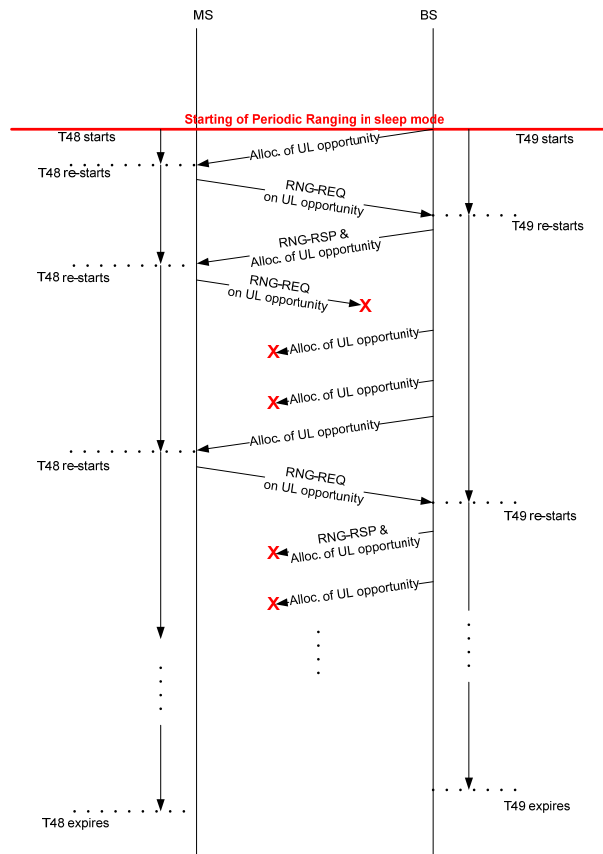

Figure 3. The proposed operation of periodic ranging during sleep mode

2.3.2 Keep-Alive check using ordinary availability intervals.

If BS does not include next_periodic ranging TLV in MOB_SLP-RSP, BS may implement keep-alive signaling by unsolicited allocating UL data grants to MS during an availability interval T4 is restarted according to Fig 90. The MS shall respond to such a data grant sending any data whereas it is clarified that an UL msg with BR=0 shall not be affect the status of current sleep mode.

BS may also during an availability interval transmit an unsolicited RNG-RSP messages with frequency, timing or power offsets, whereas MS shall use these new offsets during next time of transmitting, determined by next UL-grant. New assigned power offset shall also be used in case MS decides to wake up and perform CDMA based ranging or bandwidth request due to data in buffers.

Keep-alive algorithm including retry mechanisms at message loss is vendor specific and out of scope of the standard.

3. Proposed Text Changes

[Add new TLV encoding for REG-REQ to table 369a on Page 685 and after 11.7.26, as follows]

Table 369a—REG-REQ/RSP management message encodings (continued)

Type	Parameter	Type	Parameter
20	Maximum MAC Data per Frame Support	42	MS HO TEK Processing Time
21	Packing Support	43	MAC Header and Subheader Support
22	MAC Extended rtPS Support	44	SN Reporting Base
=	=	<u>45</u>	<u>MS timer T4</u>

11.7.27 MS periodic ranging timer information

This value indicates MS value of T4 timer, used for triggering the periodic ranging as described in 6.3.10.3.2 and illustrated in fig 90.

<u>Type</u>	<u>Length</u>	<u>Value</u>	<u>Scope</u>
<u>45</u>	<u>1</u>	<u>Positive integer representing MS timer T4 in sec.</u>	<u>REG-REQ</u>

[Append two parameters to the end of Table 342 on Page 657 as follows]

Table 342 --- Parameters and constants

System	Name	Time reference	Minimum value	Default value	Minimum Value
MS	HO Process Optimization MS Timer Retries	Number of SBC-REQ and/or REG-REQ retries while waiting for unsolicited SBC-RSP and/or	3	--	--

		REG-RSP as part of MS network re-entry and as indicated by HO Process Optimization message element of RNGRSP.			
...
...
BS	EAP Complete Resend	Total number of sending PKMv2_EAP_Complete message in double EAP mode.	1	3	3
<u>MS</u>	<u>T48</u>	<u>maximum duration that MS shall wait to receive UL transmission opportunities allocated by BS, after keep-alive check operation starts in the frame specified by Next Periodic Ranging TLV encoding(refer to 6.3.21.7.1)</u>	<u>5 sec</u>		<u>50 sec</u>
<u>BS</u>	<u>T49</u>	<u>maximum duration that BS shall wait to receive RNG-REQ messages from MS on UL transmission opportunities, after keep-alive check operation starts in the frame specified by Next Periodic Ranging TLV encoding (refer to 6.3.21.7.1)</u>	<u>5 sec</u>		<u>50 sec</u>

[Modify the paragraph of 6.3.10.3.2 in Page 207 as follows]

6.3.10.3 OFDMA-based ranging

...

6.3.10.3.2 Periodic ranging and automatic adjustments

An MS that wishes to perform periodic ranging shall take the following steps

- The SSMS, shall choose randomly a Ranging Slot (with the use of a binary truncated exponent algorithm to avoid possible re-collisions) at the time to perform the ranging, then it chooses randomly a Periodic Ranging Code (~~from the Periodic Ranging domain~~) and sends it to the BS (as a CDMAcode) and restarts timer T4.
- If the MS does not receive a response, the MS may send a new CDMA code at the next appropriate periodic Ranging transmission opportunity and adjust its power level up to PTX_IR_MAX (6.3.9.5.1).
- The BS cannot tell which SSMS sent the CDMA ranging request; therefore, upon successfully receiving a CDMA Periodic Ranging Code, the BS broadcasts a Ranging Response message that advertises the received Periodic Ranging Code as well as the ranging slot (OFDMA symbol number, subchannel, etc.) where the CDMA Periodic Ranging code has been identified. This information is used by the SS that sent the CDMA Periodic ranging code to identify the Ranging Response message that corresponds to its ranging request. The Ranging Response message contains all the needed adjustment (e.g., time, power, and possibly frequency corrections) and a status notification.
- Upon receiving a Ranging Response message with continue status, the SSMS shall continue the ranging process with further periodic ranging codes randomly chosen ~~from the Periodic Ranging domain~~.
- Using the OFDMA ranging mechanism, the periodic ranging timer is controlled by the SSMS, not the BS.
- The BS may send an unsolicited RNG-RSP as a response to a CDMA-based bandwidth-request or any other data transmission from the SSMS.
- Upon timeout of MS internal T4 timer, the MS shall perform. Periodic Ranging according to procedure above

[Modify the paragraph of 6.3.21.4 in Page 232 as follows]

6.3.21.4 Power Saving Classes of type III

Power Saving Class of this type is recommended for multicast connections as well as for management operations, for example, Periodic Ranging, DSx operations, MOB_ NBR-ADV etc. Power Saving Classes of this type are defined/activated by MOB_SLP-REQ/MOB_SLP-RSP or Bandwidth request and uplink sleep control header/DL Sleep control extended subheader transaction. The MS may retransmit MOB_SLP-REQ message (or Bandwidth request and uplink sleep control header) if it does not receive the MOB_SLP-RSP message (or DL Sleep control extended subheader) within the T43 timer. The BS may send unsolicited MOB_SLP-RSP or DL Sleep control extended subheader to initiate activation of Power Saving Class. Deactivation of Power Saving Class occurs automatically after expiration of sleep window.

Alternatively Power Saving Class of type III may be defined/activated by TLV encodings in RNG-RSP message. ~~For~~If periodic ranging Next Periodic Ranging TLV encoding is used, ~~it~~it activates special Power Saving Classes of type III associated with periodic ranging procedure (as described in 6.3.21.5.1) or keep-alive check as described in 6.3.21.7.2). In this case the sleep window of the class starts in the next frame after RNG-RSP transmitted and ends in the previous frame, which Next Periodic Ranging TLV encoding indicates.

If Next Periodic Ranging TLV encoding is included in MOB_SLP-RSP, this activates Power Saving Class of type III for periodic ranging and BS can continue to activate the Power Saving Class using Next Periodic Ranging TLV encoding in RNG-RSP message with ranging status set to success.

The following are relevant parameters except the case that Next Periodic Ranging TLV encoding is used:

- Final-sleep window base
- Final-sleep window exponent
- Start frame number for sleep window

In case Next Periodic Ranging TLV encoding is used, MS shall regard the Start frame number for sleep window as 1 frame and calculate the next frame to wake by using Next Periodic Ranging TLV encoding.

Power Saving Class becomes active at the frame specified as “Start frame number for first sleep window”. Duration of sleep window is specified as base/exponent. After the expiration of the sleep window Power Saving Class automatically becomes inactive.

For multicast service Base Station may guess when the next portion of data will appear. Then the BS allocates sleep window for all time when it does not expect the multicast traffic to arrive. After expiration of the sleep window multicast data, if already available, may be transmitted to relevant MSs. After that the BS may decide to re-activate Power Saving Class.

As an example, Power Saving Class of type III may include Basic connection to serve needs of Periodic Ranging. In this case, duration (base/exponent) of sleep window shall be equal to time interval needed before next Periodic ranging transaction. Then the MS, after the specified time interval, shall be available to DL transmission and BS may either allocate an UL transmission opportunity for RNG-REQ or send unsolicited RNG-RSP. Re-activation of the Power Saving Class may be achieved using, for example, TLVs included into RNG-REQ/RSP.

Alternatively, Power Saving Class of type III may be activated /deactivated by TLVs transmitted in RNGRSP messages.

[Modify the paragraph of 6.3.21.5 in Page 233 as follows]

6.3.21.5 Periodic Ranging in sleep mode

There are two Periodic Ranging schemes in sleep mode : CDMA code-based and Message-based Periodic Ranging.

In case of OFDMA PHY, MS performs CDMA code-based Periodic Ranging according to 6.3.21.5.2

In case of other PHYs(SC, SCa and OFDM), Message-based Periodic ranging is used as described in 6.3.21.5.1

6.3.21.5.1 Periodic Ranging in sleep mode for PHYs(SC, SCa, and OFDM)

For each MS in sleep mode, during its listening-window, BS may allocate an UL transmission opportunity for periodic ranging. Alternatively, BS may return the MS to Normal Operation by deactivation of at least one Power Saving Class to keep it in active state until assignment of a UL transmission opportunity for periodic ranging, or let the MS know when the periodic ranging opportunity shall occur with Next Periodic Ranging TLV in last successful RNG-RSP.

During periodic ranging or negotiation of sleep mode, after RNG-REQ (or MOB_SLP-REQ) reception, BS ~~may shall~~ send RNG-RSP (or MOB_SLP-RSP, respectively) including Next Periodic Ranging TLV so that MS ~~shall can~~ know when to perform periodic ranging as described in more details in 6.3.1921.4. In the frame specified by Next Periodic Ranging TLV, the MS shall decode all consequent UL-MAP messages waiting for a UL unicast transmission opportunity for periodic ranging. When such an opportunity occurs, the MS shall transmit a RNG-REQ message to the BS and then perform the regular procedure for periodic ranging. A successful periodic ranging procedure does not deactivate another Power Save Classes. In the case where periodic ranging procedure fails, the MS shall perform Initial Ranging procedure or handover to another BS. When the periodic ranging operation between MS and BS successfully processes, the BS may inform the MS of the frame number in which the next periodic ranging operation is expected to start. For that, BS shall append a Next Periodic Ranging TLV encoding to the RNG-RSP message. BS also may inform MS of the existence of DL Traffic addressed to MS. For that, BS shall include the Next Periodic Ranging TLV with a value set to zero. This deactivates all Power Saving Classes at the MS. If an MS receives the RNG-RSP message with this indication from the BS, then the MS shall immediately resume Normal Operation with the BS. The BS may include a SLPID_Update TLV item in a RNG-RSP message for an MS in sleep mode. If the serving BS receives a RNG-REQ message from an MS in sleep mode and there is any need to update SLPID assigned to the MS, the BS shall append a SLPID_Update TLV to the RNG-RSP message only for a RNGRSP message with ranging status flag set to 'success'. When the received RNG-RSP message with ranging status flag set to 'success' includes a SLPID_Update TLV, the MS shall decode the TLV and update its SLPID to the new one. The MS shall identify if the SLPID_Update TLV addresses it by searching through the SLPID_Update TLV and determining if the MS's current SLPID matches the Old_SLPID in the SLPID_Update TLV. If they match, then the MS shall set its SLPID to the New_SLPID provided in the SLPID_Update TLV.

6.3.21.5.2 Periodic Ranging in sleep mode for OFDMA PHY

Upon expiration of MS Timer T4 shown in fig 90, MS may perform CDMA-based periodic ranging message according to method described in 6.3.10.3.2. CDMA code-based Periodic Ranging can be performed during any interval or MS may skip the periodic ranging depending on vendor implementation. MS may anonymously extend its Availability interval in order to wait the reception of RNG-RSP message with ranging status = Success or find an appropriate ranging opportunity for sending/resending of CDMA code-based ranging request. Such temporary extension of Availability interval is not known by the BS and shall not affect the previously negotiated status of the sleep mode between MS and BS.

[Add the section 6.3.21.7 and its subsequent sections in page 234 as follows]

6.3.21.7 Keep-Alive check in sleep mode

In order for BS to maintain supervision of MSs in sleep mode and to perform necessary adjustments, BS may implement a keep-alive check mechanism. There are two methods for Keep-Alive check in sleep mode : Message-based and unsolicitedly grant of UL bandwidth during an availability interval. Those schemes are controlled by BS. If there is Next Periodic Ranging TLV encoding in MOB_SLP-RSP message during sleep mode negotiation, Keep-Alive check operation as described in 6.3.21.7.1 is used. Otherwise, Keep-Alive check operation described in 6.3.21.7.2 can be used.

6.3.21.7.1 OFDMA Message-based keep-alive check in sleep mode

For Keep-Alive check for an MS in sleep mode, BS may include Next Periodic Ranging TLV encoding in MOB_SLP-RSP or RNG-RSP message. In this case, BS shall allocate an UL transmission opportunity for RNG-REQ message to an MS in the frame specified by Next Periodic Ranging TLV encoding. And, MS shall transmit a RNG-REQ message on the UL burst allocated by the BS. When BS receives the first RNG-REQ message on UL burst allocated by the BS, BS shall send unconditionally a RNG-RSP with ranging status = Success including Next Periodic Ranging TLV encoding so that MS can know when to perform keep-alive operation in future. But, if the BS wants to perform additional adjustment for the MS, BS may send the RNG-RSP message with ranging status = Continue including Next Periodic Ranging TLV encoding so that the MS can know when to perform keep-alive operation in future. In this case, MS shall remain awake and perform CDMA code-based Periodic Ranging operation(refer to 6.3.10.3.2) until BS sends the RNG-RSP message with ranging status = Success. MS can enter sleep mode again till the frame indicated by the Next Periodic Ranging TLV encoding, if possible.

In the frame specified by Next Periodic Ranging TLV, when BS allocates a UL transmission opportunity to an MS, BS starts a timer T49 at the same time and wait to receive a first RNG-REQ message from the MS on the UL transmission opportunity. When BS receives the first RNG-REQ message from the MS on the UL burst, BS shall unconditionally terminate T49 timer. If BS doesn't receive a RNG-REQ message from MS on the UL burst for the MS, it shall continue to allocate a UL unicast burst to the MS as long as the T49 runs. But, if the T49 expires, BS shall regard the MS as being MAC-Initialized. On the other hand, in the frame specified by Next Periodic Ranging TLV, MS shall wake up and try to recognize an allocation of a UL unicast burst allocated by BS. MS shall start a timer T48 at the same time. MS shall reset T48 whenever it receives its own UL burst allocation without RNG-RSP message for the MS. And, MS shall terminate T48 when it receives a RNG-RSP message. MS shall maintain awake so as to receive a RNG-RSP message from BS as long as the T48 runs. If T48 timer expires, MS may perform Network Entry.

When the Keep-Alive check operation between MS and BS successfully processes, the BS shall inform the MS of the frame number in which the next Keep-Alive check operation is expected to start. For that, BS shall append a Next Periodic Ranging TLV encoding to the RNG-RSP message. If MS receives a RNG-RSP message with ranging status = Success including Next Periodic Ranging TLV encoding, MS shall recognize the frame to wake up for next Keep-Alive check. If MS receives a RNG-RSP message with ranging status = Continue including Next Periodic Ranging TLV encoding, MS shall perform CDMA code-based Periodic Ranging together with saving of the frame to wake up for next Keep-Alive check. BS

may send RNG-RSP message with Ranging Status = Abort, In this case, BS regards the MS as being MAC-Initialized and MS shall perform Network Entry to a BS.

At the time of successful Keep-Alive check, BS may inform MS of the existence of DL Traffic addressed to MS. For that, BS shall include the Next Periodic Ranging TLV with a value set to zero. This deactivates all Power Saving Classes at the MS. If an MS receives the RNG-RSP message with this indication from the BS, then the MS shall immediately resume Normal Operation with the BS. The BS may also include a SLPID Update TLV item in a RNG-RSP message for an MS in sleep mode. If BS receives a RNG-REQ message from an MS and there is any need to update SLPID assigned to the MS, the BS shall append a SLPID Update TLV to the RNG-RSP message. When MS receives RNG-RSP message with a SLPID Update TLV, the MS shall decode the TLV and update its SLPID to the new one. The MS shall identify if the SLPID Update TLV addresses it by searching through the SLPID Update TLV and determining if the MS's current SLPID matches the Old SLPID in the SLPID Update TLV. If they match, then the MS shall set its SLPID to the New SLPID provided in the SLPID Update TLV.

6.3.21.7.2 OFDMA keep alive check by UL data grants in sleep mode

BS may implement keep-alive signaling by unsolicited allocating UL data grants during an Availability interval. The MS shall respond to such a data grant sending any data whereas it is clarified that an UL message with BR=0 shall not be affect the status of current sleep mode according to 6.3.21.2.

BS may also during an availability interval transmit an unsolicited RNG-RSP messages with frequency, timing or power offsets, whereas MS shall use these new offsets during next time of transmitting, determined by next UL-grant. New assigned power offset shall also be used in case MS decides to wake up and perform CDMA based ranging or bandwidth request due to data in buffers.