

FREQUENCY DOMAIN EQUALIZATION FOR 2-11 GHZ BROADBAND WIRELESS SYSTEMS

Document Number: IEEE 80216t-01/01

Date Submitted:
2001-01-18

Source:

David Falconer⁽¹⁾ and Lek Ariyavisitakul⁽²⁾
⁽¹⁾Dept. of Systems and Computer Engineering
Carleton University
Ottawa, Ont., Canada K1S 5B6

Voice: (613) 520-5722
Fax: (613) 520-5727
E-mail: ddf@sce.carleton.ca

⁽²⁾Broadband Wireless Solutions, Atlanta

Venue:

IEEE 802.16 meeting 11, Ottawa

Base Document:

None

Purpose:

Broadband wireless systems deployed in outdoor non-line of sight environments may encounter delay spreads of over 5 to 10 μ s - which can cause potential intersymbol interference over 50 or more data symbol intervals. OFDM (orthogonal frequency division multiplexing) has been suggested to combat this ISI problem with reasonable complexity. However OFDM systems generate high transmitted peak-to-average ratios and are sensitive to phase noise; this can increase RF subsystem cost and complexity.

In this tutorial we survey recent advances in frequency domain equalization (FDE) for single carrier (SC) systems. SC modulation systems have lower peak-to-average ratios than OFDM, and when combined with FDE, their performance is at least as good as OFDM systems (in some cases better); furthermore, they have the same reduced signal processing complexity enjoyed by OFDM systems.

We introduce linear and decision feedback equalization versions of SC-FDE, and present some comparative performance results. We briefly explore the possible interoperability of OFDM and SC-FDE systems, and also present a proposal for reducing subscriber unit cost and complexity by employing OFDM in the downlink and SC-FDE in the uplink.

Notice:

This document has been prepared to assist IEEE 802.16. It is offered as a basis for discussion and is not binding on the contributing individual(s) or organization(s). The material in this document is subject to change in form and content after further study. The contributor(s) reserve(s) the right to add, amend or withdraw material contained herein.

Release:

The contributor grants a free, irrevocable license to the IEEE to incorporate text contained in this contribution, and any modifications thereof, in the creation of an IEEE Standards publication; to copyright in the IEEE's name any IEEE Standards publication even though it may include portions of this contribution; and at the IEEE's sole discretion to permit others to reproduce in whole or in part the resulting IEEE Standards publication. The contributor also acknowledges and accepts that this contribution may be made public by IEEE 802.16.

IEEE 802.16 Patent Policy:

The contributor is familiar with the IEEE 802.16 Patent Policy and Procedures (Version 1.0) <<http://ieee802.org/16/tpr/patents/policy.html>>, including the statement "IEEE standards may include the known use of patent(s), including patent applications, if there is technical justification in the opinion of the standards-developing committee and provided the IEEE receives assurance from the patent holder that it will license applicants under reasonable terms and conditions for the purpose of implementing the standard."

Early disclosure to the Working Group of patent information that might be relevant to the standard is essential to reduce the possibility for delays in the development process and increase the likelihood that the draft publication will be approved for publication. Please notify the Chair <<mailto:chair@standards.ieee.org>> as early as possible, in written or electronic form, of any patents (granted or under application) that may cover technology that is under consideration by or has been approved by IEEE 802.16. The Chair will disclose this notification via the IEEE 802.16 web site <<http://ieee802.org/16/tpr/patents/index.cfm>>.

FREQUENCY DOMAIN EQUALIZATION FOR 2-11 GHZ BROADBAND WIRELESS SYSTEMS

D. Falconer⁽¹⁾ Carleton University, Ottawa
S. L. Ariyavisitaku⁽²⁾ Broadband Wireless Solutions, Atlanta

- ddf@sce.carleton.ca
- lek@ieee.org

Background

- 2-11 GHz licensed and unlicensed systems may operate on NLOS conditions, in which severe multipath is encountered. Multipath delay spread is a major transmission problem, which affects the design of modulation and equalization.
- Delay spread varies with environment and characteristics of transmit and receive antennas. In typical outdoor non line of sight operating conditions, average delay spread $\sim 0.5 \mu\text{s}$, but 2% of measured delay spreads $>$ approx. $5\text{-}10 \mu\text{s}$ [Por00], [Erc99], [Har00].
- Corresponding intersymbol interference @ 10 Megasymbols/s could span up to about 50-100 symbols.

Delay spread here is the total spread, (approximately 4-5 times the RMS delay spread).

A Multipath Example

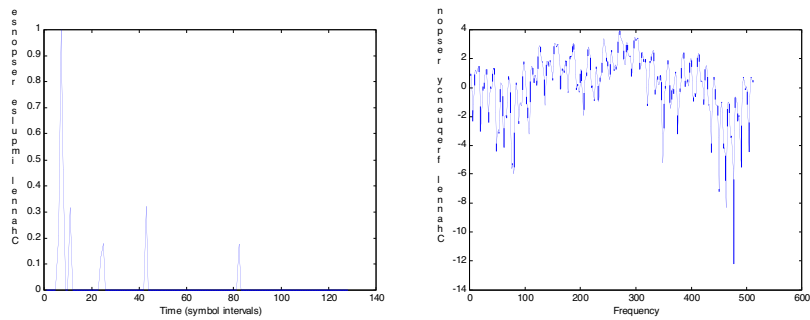

In this rather extreme example, intersymbol interference would extend over about 80 symbol intervals. Situations like this will sometimes occur in broadband wireless systems which have a symbol rate of say, 5 Msymbols/s, and which are deployed with omnidirectional or somewhat directional antennas in suburban and urban environments [Erc99], [Por00], [Har00].

Alternative High Bit rate Modulation Approaches for Severe Multipath

- OFDM (Orthogonal frequency division multiplexing) - less complex than conventional time domain processing [Sar95], [McD96], but has a power backoff penalty [Cim00].
- Single carrier modulation, with receiver linear equalization (LE) or decision feedback equalization (DFE) in frequency domain - approximately equal complexity to OFDM, without the power backoff penalty [Sar95], [Cla98], [Tar00], [Van00].
- An adaptive receiver based on frequency domain processing can handle both OFDM and single carrier modulation!

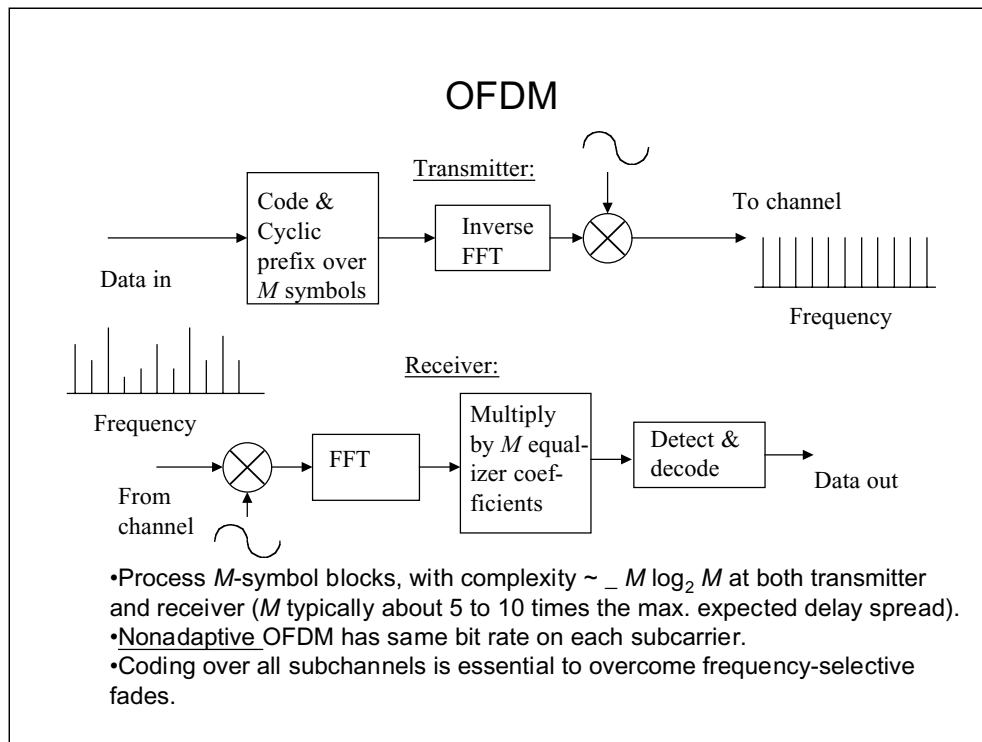

OFDM transmits multiple modulated subcarriers in parallel. Each occupies only a very narrow bandwidth. Since only the amplitude and phase of each subcarrier is affected by the channel, compensation of frequency selective fading is done by compensating for each subchannel's amplitude and phase. OFDM signal processing is carried out relatively simply by using two fast Fourier transforms (FFT's), at the transmitter and receiver, respectively.

There are approximately $\log_2 M$ multiplies per symbol, counting both transmitter and receiver operations. A variation is adaptive OFDM, where the signal constellation on each subchannel depends on channel response at that frequency. It requires feedback from the receiver to the transmitter. It is not commonly employed in radio systems due to complexity and to channel time variations. In non-adaptive OFDM, coding and interleaving are essential to compensate for subchannels which are severely attenuated.

Because the transmitted OFDM signal is a sum of a large number (M) of slowly modulated subcarriers, it has a high peak to average ratio, even if low level modulation like QPSK is used on each subcarrier. While there are signal processing methods to reduce this ratio [Cim00], [Tar00], [Van00], the transmitter power amplifier in a OFDM system must be backed off more than that of a single carrier system. This is especially important for subscribers near the edge of a cell, with large path loss, where QPSK modulation must be used; the increased power backoff required in this situation for OFDM would increase the cost of the power amplifier.

Single Carrier with Frequency Domain Equalization(SC-FDE) with Linear Equalization

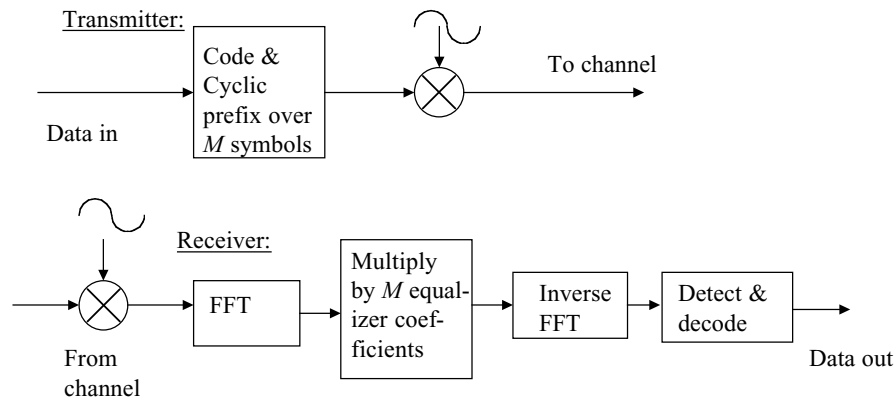

- The number of FFT's and the total number of complex multiplies is the same as for OFDM.
- The block length M and cyclic prefix are similar to those for OFDM.

The single carrier system transmits a single carrier, modulated at a high symbol rate. Frequency domain equalization in a SC system is simply the frequency domain analog of what is done by a conventional linear time domain equalizer. For channels with severe delay spread it is simpler than corresponding time domain equalization for the same reason that OFDM is simpler: because of the FFT operations and the simple channel inversion operation.

What is shown above is essentially conventional linear equalization, using a transversal filter with M tap coefficients, but with filtering done in the frequency domain. The typical block length M , suitable for MMDS systems, would be in the range of 128 to 1024, for both OFDM and single-carrier FDE systems. There are approximately $\log_2 M$ multiplies per symbol, as in OFDM.

OFDM and SC-FDE – Signal Processing Similarities and Differences

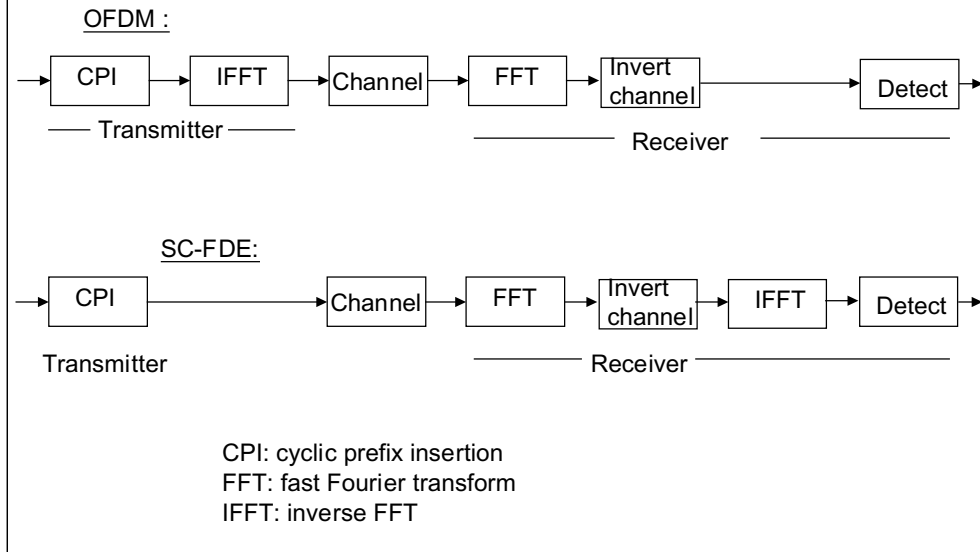

The main hardware difference between OFDM and SC-FDE is that the transmitter's inverse FFT block is moved to the receiver. The complexities are the same. A dual-mode system could be designed to handle either OFDM or SC-FDE by simply interchanging the IFFT block between the transmitter and receiver at each end. (See the next slide).

Both systems can be enhanced by coding (which is in fact required for OFDM systems), adaptive modulation and space diversity. In addition, OFDM can incorporate peak-to-average reduction signal processing to partially (but not completely) alleviate its high sensitivity to power amplifier nonlinearities. SC-FDE can be enhanced by adding decision feedback equalization or maximum likelihood sequence estimation.

Potential Interoperability of OFDM and SC-FDE: - A “Convertible” Modem

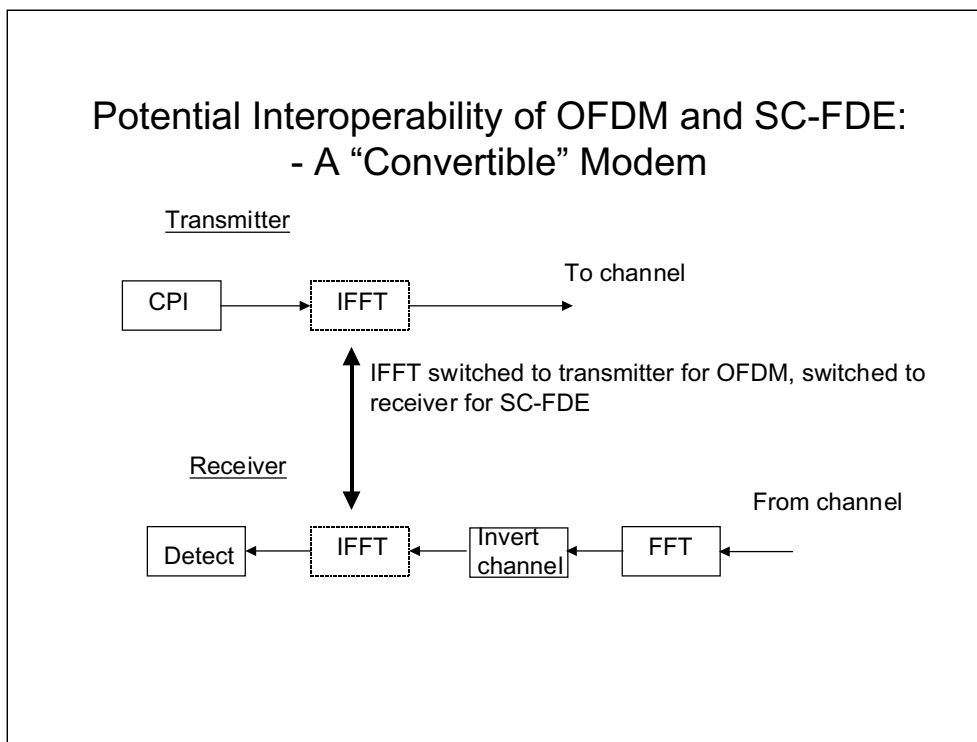

Comparable SC-FDE and OFDM systems would have the same block length and cyclic prefix lengths. Since their main hardware difference is the location of the inverse FFT, a modem could be converted as required to handle both OFDM and single carrier signals by switching the location of the inverse FFT block between the transmitter and receiver.

Block Processing in Frequency Domain Equalization

- Data symbols $\{a_n\}$ are transmitted in blocks of $(M+L)$ symbols, with a cyclic prefix of length $L >$ expected channel impulse response length.
- Receiver processes blocks of M symbol intervals.
- Typically M is 5 to 10 times L .
- First and last L symbols may be training symbols.

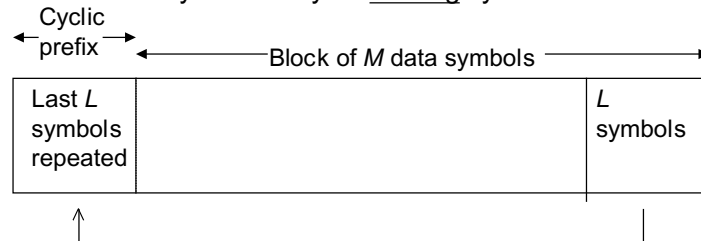

- The cyclic prefix (used in both SC-DFE and OFDM systems) at the beginning of each block has two main functions:
 - It prevents contamination of a block by intersymbol interference from the previous block.
 - It makes the received block appear to be periodic with period M , which is essential to the proper functioning of the fast Fourier transform operation.
- If the first L and last L symbols are identical sequences of training symbols, the overhead fraction is $2L/(M+2L)$.
- For either OFDM or SC-FDE MMDS systems in severe outdoor multipath environments, typical values of M could be 512 or 1024, and typical values of L could be 64 or 128.

SC-FDE With Linear Equalizer (FD-LE)

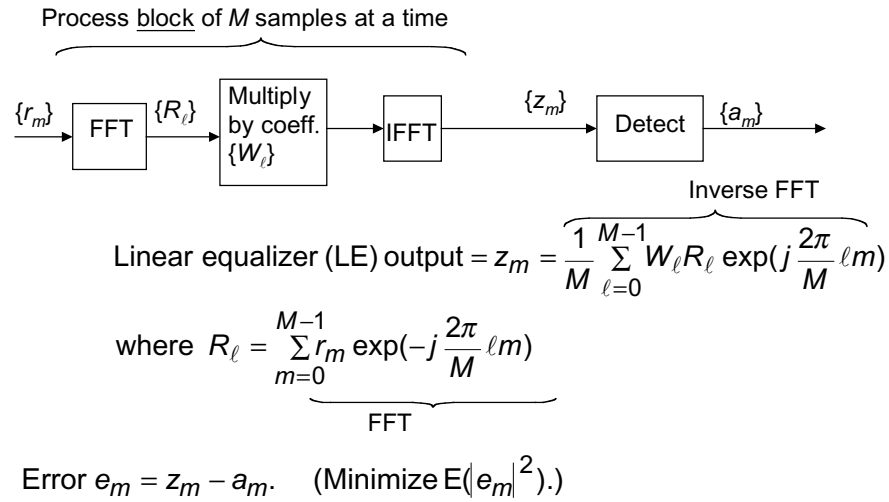

- Use cyclic prefix, as in OFDM.
- $M \log_2 M + M + M \log_2 M = 2M \log_2 M + M$ operations per block of M symbols (i.e. $\log_2 M + 1$ per symbol).
- A comparable time domain equalizer would do M^2 operations on a block of M (i.e. M per symbol).

SC-FDE Decision Feedback Equalizer (FD-DFE)

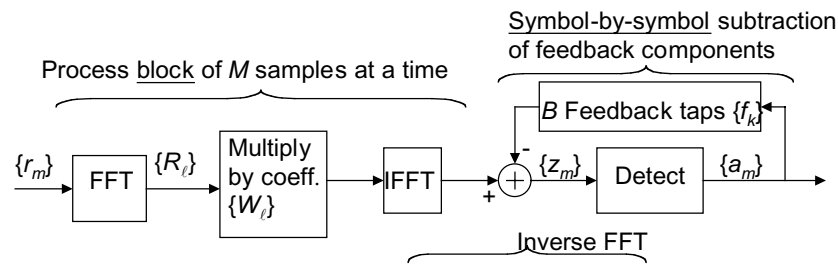

$$\text{DFE output} = z_m = \frac{1}{M} \sum_{\ell=0}^{M-1} W_{\ell} R_{\ell} \exp(j \frac{2\pi}{M} \ell m) - \sum_{k \in F_B} f_k^* a_{m-k}$$

$$\text{where } R_{\ell} = \underbrace{\sum_{m=0}^{M-1} r_m \exp(-j \frac{2\pi}{M} \ell m)}_{\text{FFT}}$$

F_B is a set of B feedback tap delays corresponding to the B largest channel impulse response postcursors.

Error $e_m = z_m - a_m$. (Minimize $\text{MSE} = E(|e_m|^2)$.)

- Use cyclic prefix, as in OFDM.
- B would be much less than M and delay spread
- The main virtue of a DFE over a linear equalizer is its reduced noise enhancement for severely frequency-selective channels. This results in superior minimum mean squared error (MSE) performance.

Parameter Optimization for Frequency Domain DFE (for Known Channel $\{H_\ell\}$ and Noise Variance σ^2)

For $\{H_\ell, \ell=0,1,\dots,M-1\}$ = channel frequency response, can show
MSE is minimized with:

$$W_\ell = \frac{H_\ell^* \sum_{k \in F_B} f_k^* \exp(-j \frac{2\pi \ell k}{M})}{|H_\ell|^2 + \sigma^2}, \quad \ell = 0,1,2,\dots,M-1$$

$\mathbf{f} = -\mathbf{V}^{-1}\mathbf{v}$, where $f_0 = 1$,

$$\mathbf{V} = \begin{bmatrix} v_0 & v_{k_1}^* & \cdot & v_{k_{B-1}}^* \\ v_{k_1} & v_0 & v_{k_1}^* & \cdot \\ \cdot & \cdot & \cdot & \cdot \\ v_{k_{B-1}} & \cdot & \cdot & v_0 \end{bmatrix}, \quad \mathbf{f} = \begin{bmatrix} f_{k_1} \\ f_{k_2} \\ \cdot \\ f_{k_B} \end{bmatrix}, \quad \mathbf{v} = \begin{bmatrix} v_{k_1} \\ v_{k_2} \\ \cdot \\ v_{k_B} \end{bmatrix}$$

$$\text{and } v_k = \frac{1}{M} \sum_{\ell=0}^{M-1} \frac{\sigma^2}{|H_\ell|^2 + \sigma^2} \exp(-j \frac{2\pi \ell k}{M}) \quad k \in F_B = \{k_1, k_2, \dots, k_B\}$$

F_B is a set of B feedback tap delays corresponding to the B largest channel impulse response postcursors.

• For a linear equalizer, only the first equation for the $\{W_\ell\}$ is relevant, with $f_0=1$ and all other $f_k=0$. It is approximately inverting the channel's frequency response.

Example: 3-Path Channel

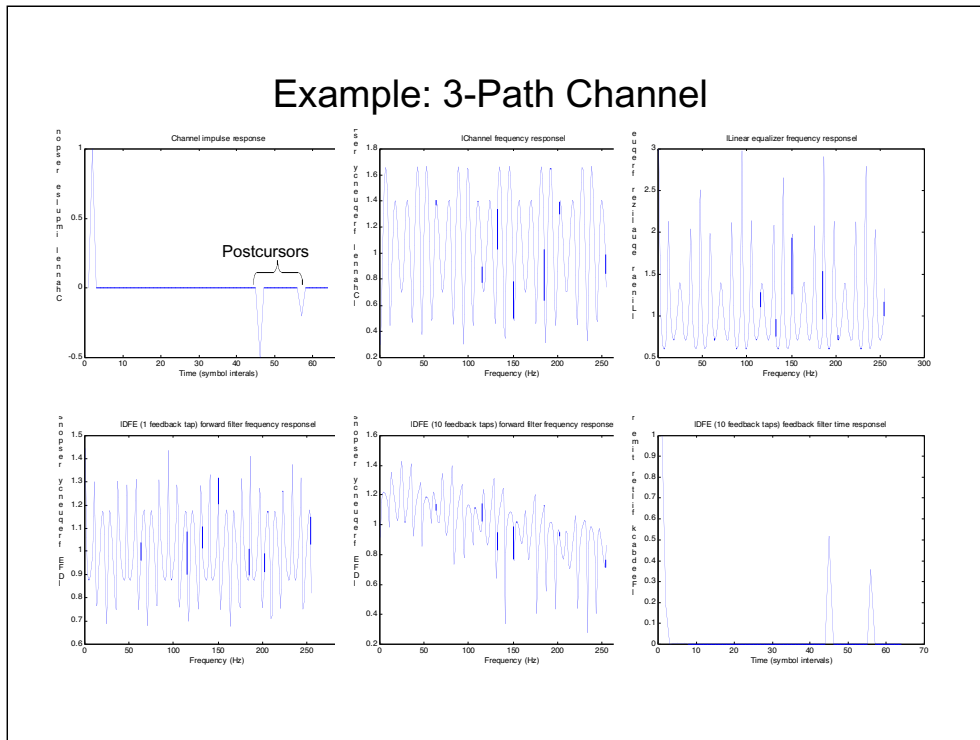

- The forward channel frequency response for the linear equalizer has large gain at frequencies where the channel gain is low. This enhances the noise power at these frequencies.
- The 1-tap and 10-tap DFE s show less noise enhancement, especially the 10-tap DFE.
- The 10-tap DFE s feedback filter response closely mimics that of the original channel. The 10 non-zero feedback tap delays are chosen to correspond to the largest channel response postcursors.

Training and Tracking Adaptation for SC-FDE

Downlink in continuous transmission mode:

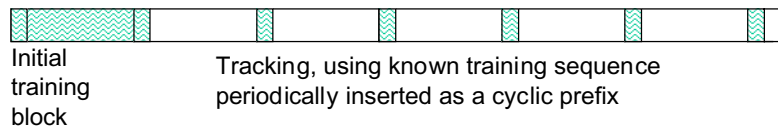

Uplink in burst mode:

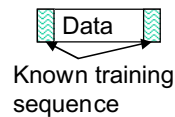

For FFT block length M and cyclic prefix length L , the fraction of training overhead in continuous mode is $L/(M+L)$. The fraction of training overhead in the burst mode is $2L/(M+2L)$. E.g. for $L=64$, $M=512$, $L/(M+L) = 11\%$.

The channel impulse response can be estimated and tracked, and then converted to the frequency domain, using correlation with the training sequence. During tracking, when the training sequences are shorter than the FFT block length M , interpolation in the frequency domain is used to extend the length to M . Channel tracking accuracy can be enhanced by using decision-directed estimation. Analogous training, tracking and interpolation approaches can be used for OFDM [Li00].

Parameter Adaptation for Frequency Domain DFE (for $N > 1$ Training Blocks)

For N ($N \geq 2$) training blocks of length M , with received samples
 $\{r_m^{(n)}; m = 0, 1, \dots, M-1; n = 1, 2, \dots, N\}$, and known training symbols
 $\{a_m^{(n)}; m = 0, 1, \dots, M-1; n = 1, 2, \dots, N\}$:

$$W_\ell = \frac{\sum_{n=1}^N R_\ell^{(n)*} A_\ell^{(n)} \sum_{k \in FB} f_k^* \exp(-j \frac{2\pi \ell k}{M})}{\sum_{n=1}^N |R_\ell^{(n)}|^2}, \quad \ell = 0, 1, 2, \dots, M-1$$

Adaptation can also be done by estimating the channel frequency response
over N training blocks as

$$H_\ell = \frac{1}{N} \sum_{n=1}^N \frac{R_\ell^{(n)}}{A_\ell}$$

, estimating the noise variance, and substituting in the expression for the
optimal parameters. This estimation can also be done in the time domain.

$A_\ell^{(n)}$ is the FFT of the overall training sequence. It is known and would be pre-computed. In most cases, it would be the same for each block; i.e. $A_\ell^{(n)} = A_\ell$. For a linear equalizer, $f_k = 1$, the rest of the $\{f_k\}$ are not computed. A good choice for a training sequence is a constant amplitude zero periodic correlation (CAZAC), such as a Frank sequence [Fra62]. P -phase Frank sequences, of length P^2 PSK symbols, with zero periodic autocorrelation (and corresponding flat frequency characteristic) can be constructed; e.g. 8 — phase sequence of length 64. Arbitrary length codes can also be constructed [Chu72].

Parameter Adaptation for Frequency Domain DFE (for $N > 1$ Training Blocks) (cont.)

$\mathbf{f} = -\mathbf{V}^{-1}\mathbf{v}$, where $f_0 = 1$,

$$\mathbf{V} = \begin{bmatrix} v_0 & v_{k_1}^* & \cdot & v_{k_{B-1}}^* \\ v_{k_1} & v_0 & v_{k_1}^* & \cdot \\ \cdot & \cdot & \cdot & \cdot \\ v_{k_{B-1}} & \cdot & \cdot & v_0 \end{bmatrix}, \quad \mathbf{f} = \begin{bmatrix} f_{k_1} \\ f_{k_2} \\ \cdot \\ f_{k_B} \end{bmatrix}, \quad \mathbf{v} = \begin{bmatrix} v_{k_1} \\ v_{k_2} \\ \cdot \\ v_{k_B} \end{bmatrix}$$

$$\text{and } v_k = \frac{1}{M} \sum_{\ell=0}^{M-1} \left[\frac{\sum_{n=1}^N |A_\ell^{(n)}|^2}{\sum_{n=1}^N |R_\ell^{(n)}|^2} - \frac{\left| \sum_{n=1}^N R_\ell^{(n)*} A_\ell^{(n)} \right|^2}{\sum_{n=1}^N |R_\ell^{(n)}|^2} \right] \exp(-j \frac{2\pi \ell k}{M}) \quad k \in F_B = \{k_1, k_2, \dots, k_B\}$$

where

$$R_\ell^{(n)} = \sum_{m=0}^{M-1} r_m^{(n)} \exp(-j \frac{2\pi \ell m}{M}) \quad \text{and} \quad A_\ell^{(n)} = \sum_{m=0}^{M-1} a_m^{(n)} \exp(-j \frac{2\pi \ell m}{M})$$

Estimated Complexity for Equalization (Number of Complex Multiplies Per Symbol)

- $\log_2 M$ for FFT and inverse FFT
- plus $(1+B)$ for decision feedback equalization.
- Total = $\log_2 M + 1 + B$.
- For linear equalizer, $B=0$, and total = $\log_2 M + 1$.
- Compare with $\log_2 M + 1$ for OFDM (including transmitter inverse FFT)

The linear SC-FDE and OFDM have the same complexity.

Estimated Complexity for Training (# Complex Multiplies and Divides Per N Training Blocks of M training Symbols Each)

- $_NM\log_2M$ to calculate $\{\mathbf{R}_\ell^{(n)}\}$
 - $2NM + M + _M\log_2M$ to calculate $\{v_k\}$
 - $5/2B^2 - 5/2B + 1$ to calculate $\{f_k\}$ using Levinson recursion.
 - $_M\log_2M + M$ to calculate $\{W_\ell\}$
- Total = $(_N+1)M\log_2M + 2(N+1)M + 5/2B^2 - 5/2B + 1$ complex multiplies and divides.
- cf. $_NM\log_2M + 2NM$ for computing $\{W_\ell\}$ in OFDM

• $\{A_\ell^{(n)}\}$ would be pre-computed and stored.

Multipath Channel Delay Spread Profiles Used for Performance Evaluations [Har00]

SUI-2:
0 dB, -3 dB, and -8 dB
Ricean-fading taps (K=5)

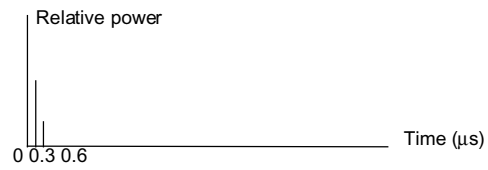

SUI-5:
0 dB, -3 dB, and -5 dB
Rayleigh-fading taps

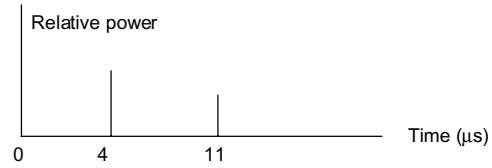

SUI-6:
0 dB, -10 dB, and -12 dB
Rayleigh-fading taps

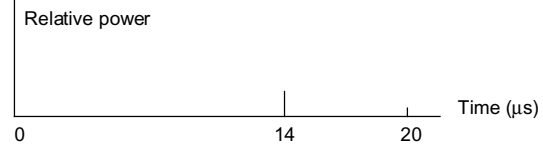

Monte Carlo BER Comparison of Frequency Domain Linear and Decision Feedback Equalization –SUI-6 Channel

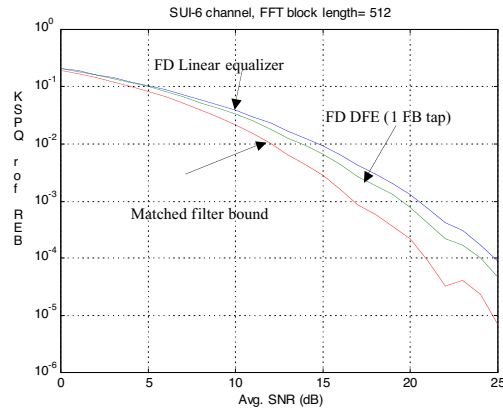

Conditions:

- SUI-6 3-tap Rayleigh fading channel ($K=0$), with $5.2 \mu\text{s}$ rms delay spread, and echoes at 0, 14 and $20 \mu\text{s}$ delays, with corresponding relative powers 0, -10 and -12 dB.

- 5 Mbaud QPSK single-carrier signal.

- Excess bandwidth rolloff=0.1.

- Linear equalization and forward DFE filtering done in frequency domain, using 512-symbol FFT blocks.

- Equalizer performance calculated from min. mean squared error expressions, assuming channel response and white noise variance are known (i.e. channel estimation and channel dynamics not included). The curves result from Monte Carlo evaluation, with 10,000 channel realizations per value of SNR.

- DFE has one time-domain feedback tap, with delay equal to maximum multipath echo delay in channel's impulse response.

- Matched filter bound corresponds to case of very low symbol rate, so there is no intersymbol interference. Curve closely follows theoretical expression, given in Proakis for 3-component diversity with same SNR's as in SUI-6 model.

10⁻³ BER Outage –SUI-6 Channel

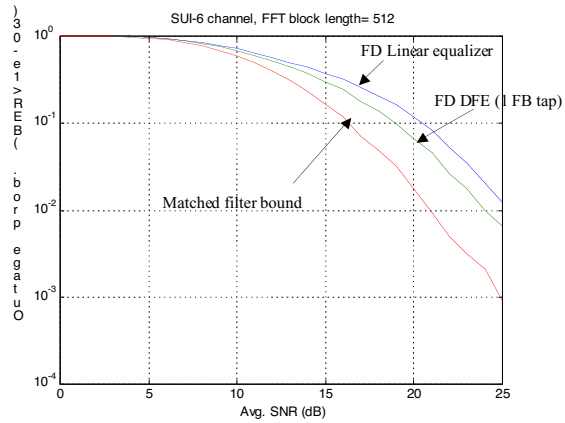

Monte Carlo BER Comparison of Frequency Domain Linear and Decision Feedback Equalization –SUI-5 Channel

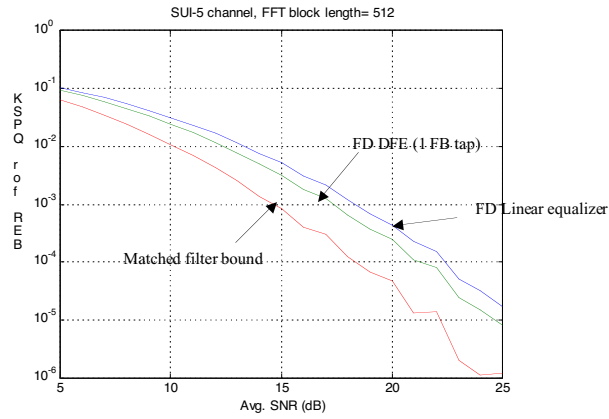

•SUI-5 3-tap Rayleigh fading channel ($K=0$), with $3.1 \mu\text{s}$ rms delay spread, and echoes at 0, 4 and $11 \mu\text{s}$ delays, with corresponding relative powers 0, -3 and -5 dB .

10⁻³ BER Outage –SUI-5 Channel

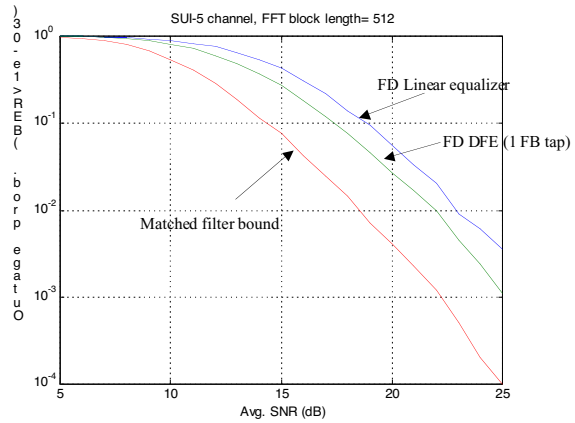

Monte Carlo Performance Comparison of Frequency Domain Linear and Decision Feedback Equalization –SUI-2 Channel

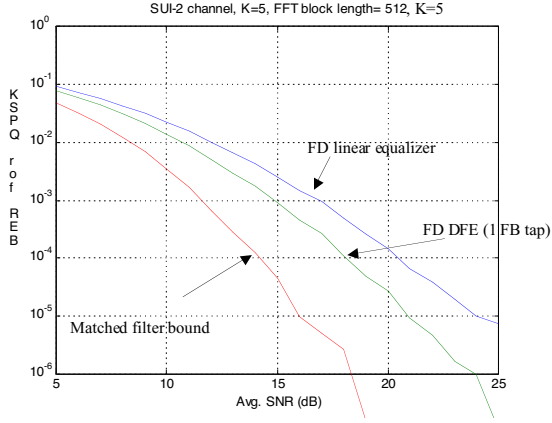

•Rician fading, with $K=5$ on each tap. 3 taps with 0, 0.3 and 0.6 μ s. delays, and corresponding relative powers of 0, -3 and -8 dB. RMS delay spread=0.2 μ s.

10⁻³ BER Outage –SUI-2 Channel

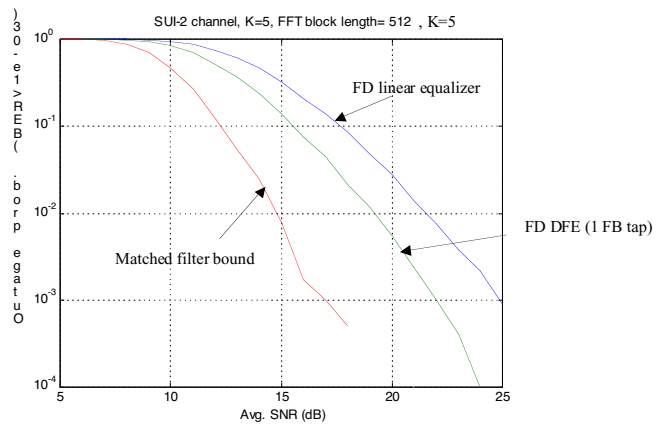

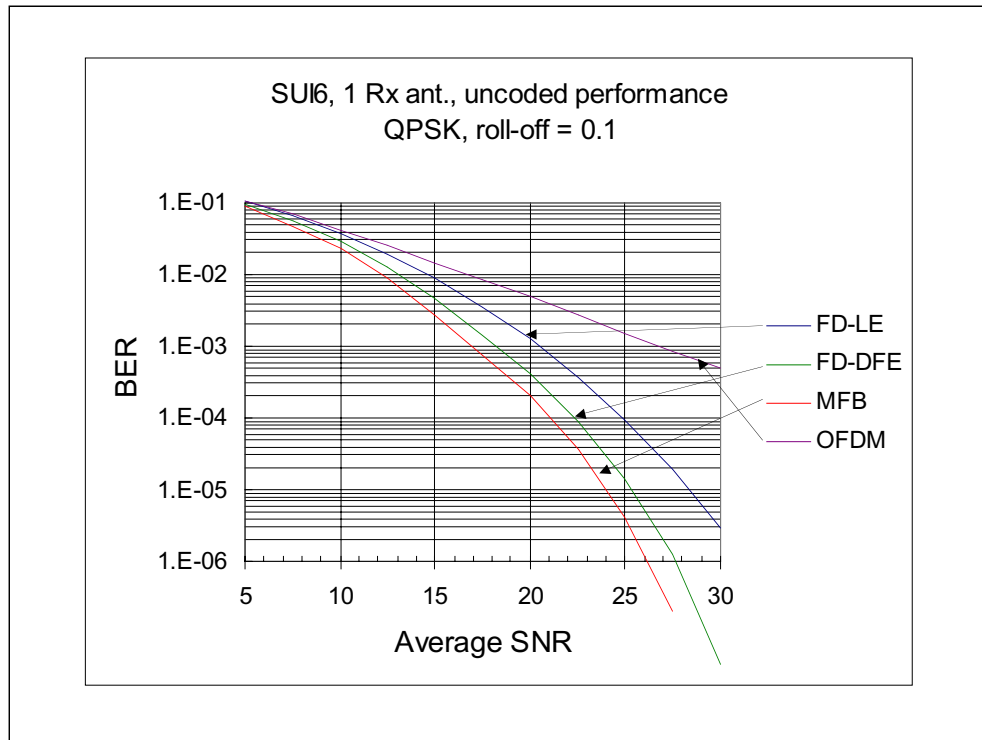

• Monte Carlo BER performances of frequency domain equalizers over multipath Rayleigh fading:

- 1.*** Frequency domain linear equalizer (FD-LE)
- 2.*** Frequency domain decision feedback equalizer (FD-DFE) without decision errors
- 3.*** Matched filter bound (MFB), representing the ultimate (hypothetical) ideal performance assuming perfect capturing of multipath energy and no loss due to intersymbol interference (ISI)
- 4.*** Uncoded OFDM performance also provided in the first 4 figures

• Channel Model: SUI6 with Rician factor $K=0$ (i.e., Rayleigh) for all paths. No diversity

• Simulation conditions: QPSK with 0.1 roll-off, 10,000 fading channel realizations, 512 point FFT, quasi-static fading, no channel estimation errors. Sufficient number of feedback taps (feedback filter is as long as the channel span). The BER for each channel realization is computed using analytical formulae.

• BER is given as a function of the per-branch SNR averaged over Rayleigh fading.

• Uncoded OFDM results are obtained by averaging the BERs on individual tones. Since each tone is a complex Gaussian random process regardless of the channel model, the overall performance for any delay profile is the same as the BER averaged over flat Rayleigh fading (so, we can also regard the uncoded OFDM results as the flat fading performance for any system).

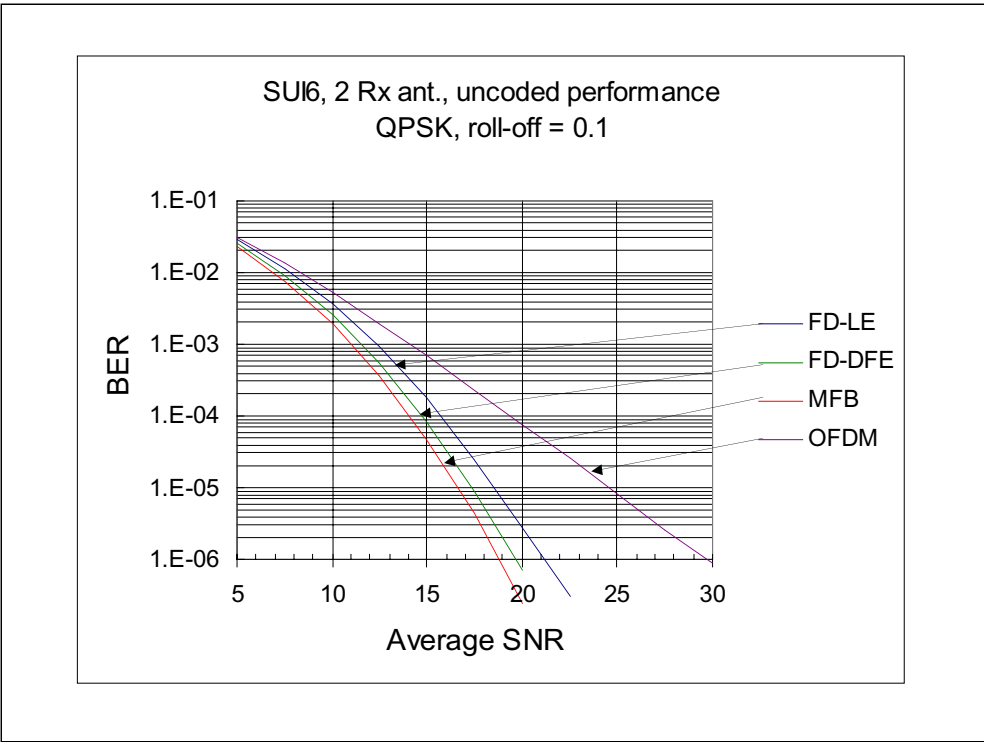

•SUI-6 with 2-branch diversity.

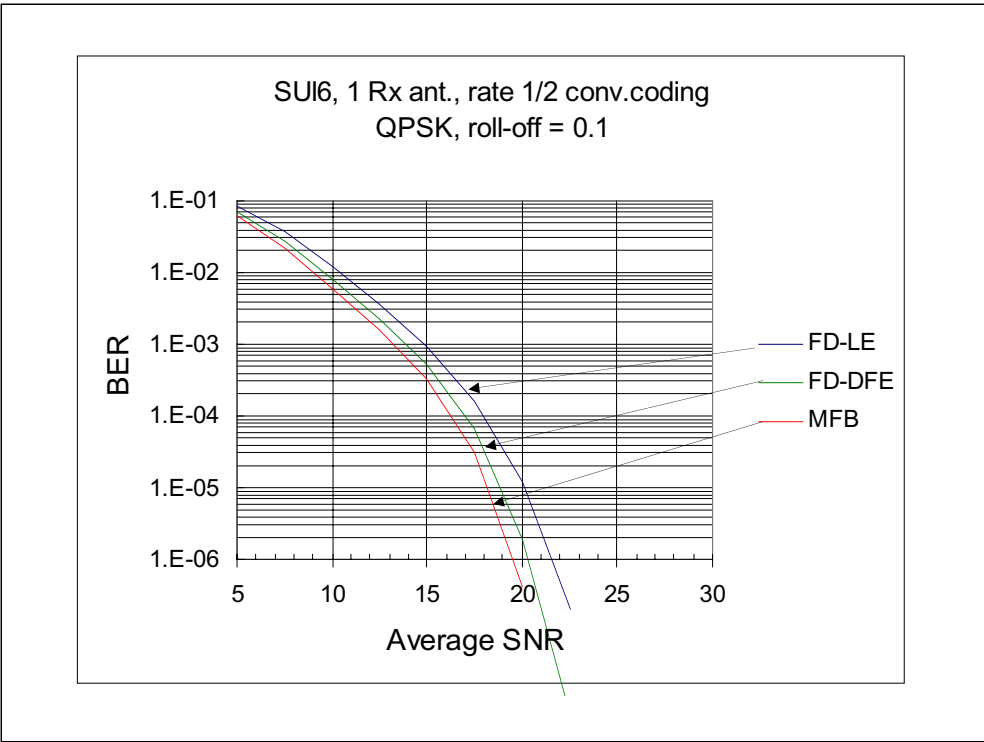

•SUI-6 with no diversity, and rate _ convolutional coding, 64 states.

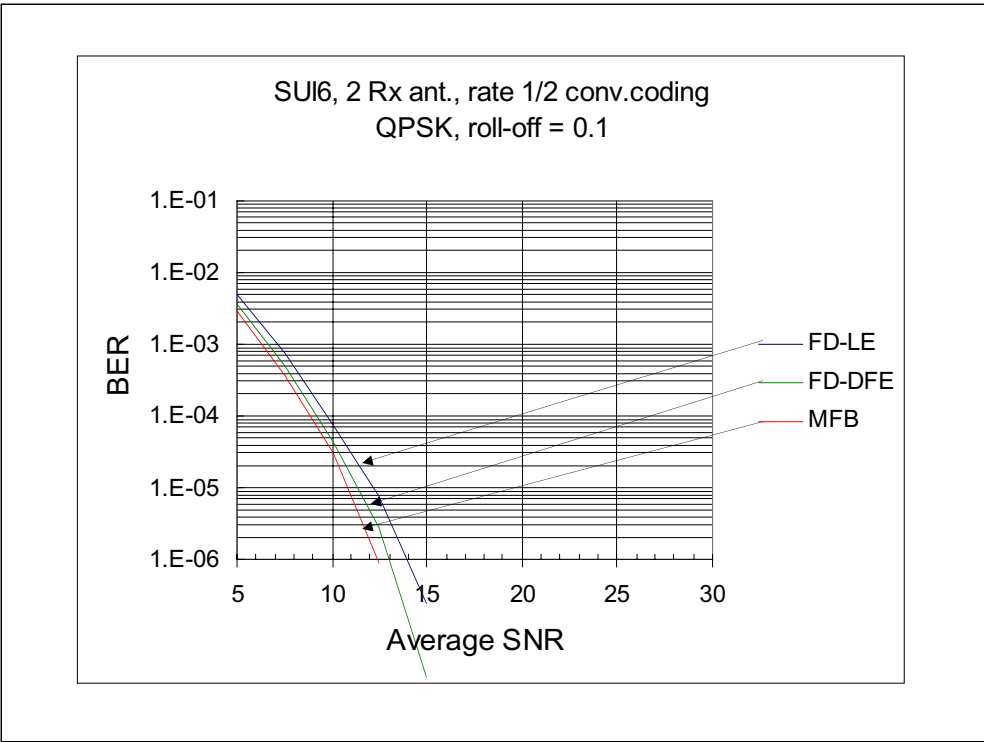

•SUI-6 with 2-antenna diversity, and rate $\frac{1}{2}$ convolutional coding.

Summary and Conclusions

- For severe multipath, single carrier QAM with simplified frequency-domain equalization performs at least as well as OFDM (better for uncoded systems).
- Frequency domain linear equalization has essentially the same complexity as uncoded OFDM, with better performance in frequency selective fading, and without OFDM's inherent backoff power penalty.
- A "convertible" frequency domain receiver structure can be programmed to handle either OFDM or single carrier.
- Downlink OFDM / uplink single carrier may yield potential complexity reduction and uplink power efficiency gains relative to downlink OFDM / uplink OFDM.

• It is not surprising to see that all the single carrier frequency domain equalizers outperform OFDM in an uncoded case. The equalizers automatically exploit the so-called inherent or built-in multipath diversity (also called frequency diversity). OFDM can exploit multipath or frequency diversity only through coding across the tones.

• Performances for SUI-2 and SUI-6 are similar (slightly better for SUI-6 because of the higher degree of frequency selectivity).

• In the uncoded case, FD-DFE outperforms FD-LE by about 2 to 4 dB (at BER below 0.001) without diversity. The gap increases with average SNR because of the noise enhancement effect. Conversely, when thermal noise is more dominant, the FD-LE will try less to invert the null, thereby causing less noise enhancement.

• With diversity, the performance difference between FD-DFE and FD-LE is reduced to about 0.8 to 1.8 dB. Two effects interplay to reduce the difference: (i) MMSE diversity [Cla98] i.e., the receiver automatically sets antenna weights to either provide diversity gain or reduce ISI, depending on which gives the smaller mean-square error outcome. (ii) With diversity, the receiver achieves the desired BER at a lower average SNR, and therefore the noise enhancement effect described above is less significant.

• From the above finding, it is suspected that the gap between FD-DFE and FD-LE performances should also be reduced when coding is used (again, because with coding, the receiver operates at a low SNR range and this should result in lower noise enhancement). The coded performance verify this point. As you can see, even without diversity, FD-LE performs only about 1 dB worse than FD-DFE.

Summary and Conclusions (cont.)

- Linear FD (FD-LE) equalization is slightly simpler than FD-DFE equalization, and approaches it in performance, especially for coded systems with space diversity. FD-DFE is an option which does not affect the transmitted air interface.
- The considered equalizer techniques can be combined with spatial arrays at transmitter and/or receiver.

• Time-domain linear equalizers with finite numbers of taps are usually not recommended for wireless channels, due to frequent occurrences of delayed paths with approximately equal power (resulting in deep spectral nulls) and the inability for finite taps to completely cancel such delayed paths. However, FD-LE effectively synthesizes an infinite-length filter (a pole filter), making it more suitable to handle channels with deep spectral nulls.

• It appears that FD-LE is sufficient for MMDS, especially when combined with space diversity or powerful coding. We can add FD-DFE as an option in the proposal (note that its presence or absence would not affect the transmitted air interface, but is an option for the manufacturer). FD-LE has the following significant advantages:

• 1. It performs within about 1 dB of FD-DFE performance when coding is used. The 1-dB improvement does not seem to justify the added complexity for implementing a feedback filter. **With FD-LE, the overall complexity is exactly the same as OFDM, i.e., $M \log M + M$.**

• 2. Bear in mind also that the FD-DFE performance assumes correct feedback. In reality, the best way to minimize error propagation in FD-DFE involves using soft and delayed decisions [Ari98] This complicates the receiver and precludes interleaving within each block. And after all is said and done, it is likely to result in a deficit (**the loss due to error propagation is likely to be greater than the 1-dB improvement achieved by ideal FD-DFE**).

• 3. A FD-DFE with one feedback tap is simple and may be an attractive option for gaining several dB in performance over the FD-LE.

• Another advantage of single carrier is that channel estimation can be done in time-domain with only a training sequence as long as the channel span [Ari98a], excluding the cyclic prefix. So, the overhead is quite low.

References

References

- [Ari98] S.L. Ariyavisitakul and Y. Li, "Joint Coding and Decision Feedback Equalization for Broadband Wireless Channels", *IEEE J. Sel. Areas in Commun.*, Vol. 16, No. 9, Dec., 1998, pp. 1670-1678.
- [Ari98a] S.L. Ariyavisitakul and G.M. Durant, "A Broadband Wireless Packet Technique Based on Coding, Diversity and Equalization", *IEEE Communications*, Vol. 36, No. 7, July 1998, pp. 110-115.
- [Ari99] S. Ariyavisitakul, J.H. Winters and I. Lee, "Optimum Space-Time Processors with Dispersive Interference: Unified Analysis and Required Filter Span", *IEEE Trans. Commun.*, Vol. 47, No. 7, July 1999, pp. 1073-1083.
- [Aue98] V. Aue, G.P. Fettweis and R. Valenzuela, "Comparison of the Performance of Linearly Equalized Single Carrier and Coded OFDM over Frequency Selective Fading Channels Using the Random Coding Technique", *Proc. ICC '98*, p. 753-757.
- [Ber95] K. Berberidis and J. Palicot, "A Frequency Domain Decision Feedback Equalizer for Multipath Echo Cancellation", *Proc. Globecom '95*, Singapore, Dec. 1995. p. 98-102.
- [Cim00] L.J. Cimini, Jr., and N.R. Sollenberger, "Peak-to-Average Power Ratio Reduction of an OFDM Signal Using Partial Transmit Sequences", *IEEE Comm. Letters*, Vol. 4, No. 3, March 2000, p. 86-88.
- [Cla98] M.V. Clark, "Adaptive Frequency-Domain Equalization and Diversity Combining for Broadband Wireless Communications", *IEEE JSAC*, Vol. 16, No. 8, Oct. 1998, pp. 1385-1395.
- [Chu72] D.C. Chu, "Polyphase Codes with Good Periodic Correlation Properties", *IEEE Trans. Information Theory*, July, 1972, pp. 531-532.
- [Czy97] A. Czylik, "Comparison Between Adaptive OFDM and Single Carrier Modulation with Frequency Domain Equalization", *Proc. VTC '97*, Phoenix, May 1997, p. 865-869.
- [Erc99] V. Erceg, D.G. Michelson, S.S. Ghassemzadeh, L.J. Greenstein, A.J. Rustako, P.B. Guerlain, M.K. Dennison, R.S. Roman, D.J. Barnickel, S.C. Wang and R.R. Miller, "A Model for the Multipath Delay Profile of Fixed Wireless Channels", *IEEE J. Sel. Areas in Communications*, Vol. 17, No. 3, March, 1999, pp. 399-410.

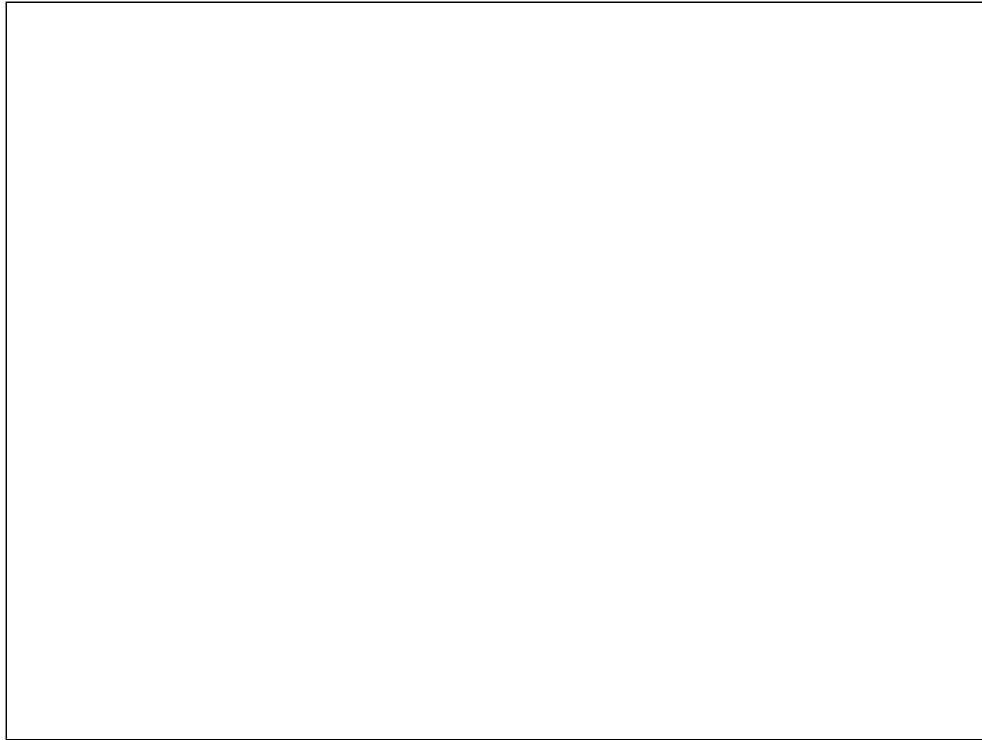

- [Fal99a] D. Falconer and R. Saini, IEEE 802.16pc-99/28, "Equalization Requirements for Millimeter Wave Fixed Broadband Wireless Access Systems" Aug. 18, 1999.
- [Fal99b] D. Falconer, IEEE802.16pc-00/01, "Multipath Measurements and Modelling for Fixed Broadband Wireless Systems in a Residential environment", Dec. 20, 1999.
- [Fal00], IEEE802.16.3c-00/13, "Modulation and Equalization Criteria for 2-11 GHz Fixed Broadband Wireless Systems", Aug. 24, 2000.
- [Fra62] R.L Frank and S.A. Zadoff, "Phase Sift Codes with Good Periodic Correlation Properties", IRE Trans. Information Theory, Oct., 1962, pp. 381-382.
- [Har00] K.V.S. Hari and C. Bushue, IEEE 802.16.3c-00-49r2, "Interim Channel Models for G2 MMDS Fixed Wireless Applications", Nov. 15, 2000.
- [Kad97] G. Kadel, "Diversity and Equalization in Frequency Domain – A robust and Flexible Receiver Technology for Broadband Mobile Communications Systems", Proc. VTC '97, Phoenix.
- [Li00] Y. Li, "Pilot-Symbol-Aided Channel Estimation for OFDM in Wireless Systems", IEEE Trans. Vehic. Technol., Vol. 49, No. 4, July, 2000, pp. 1207-1215.
- [McD96] J.T.E. McDonnell and T.A. Wilkinson, "Comparison of Computational Complexity of Adaptive Equalization and OFDM for Indoor Wireless Networks", Proc. PIMRC '96, Taipei, p. 1088-1090.
- [Pol95] T. Pollet, M. Van Bladel and M. Moeneclaey, "BER Sensitivity of OFDM Systems to Carrier Frequency Offset and Wiener Phase Noise", IEEE Trans. Commn., Vol. 43, No. 2/3/4, Feb./Mar./Apr. 1995, pp. 191-193.

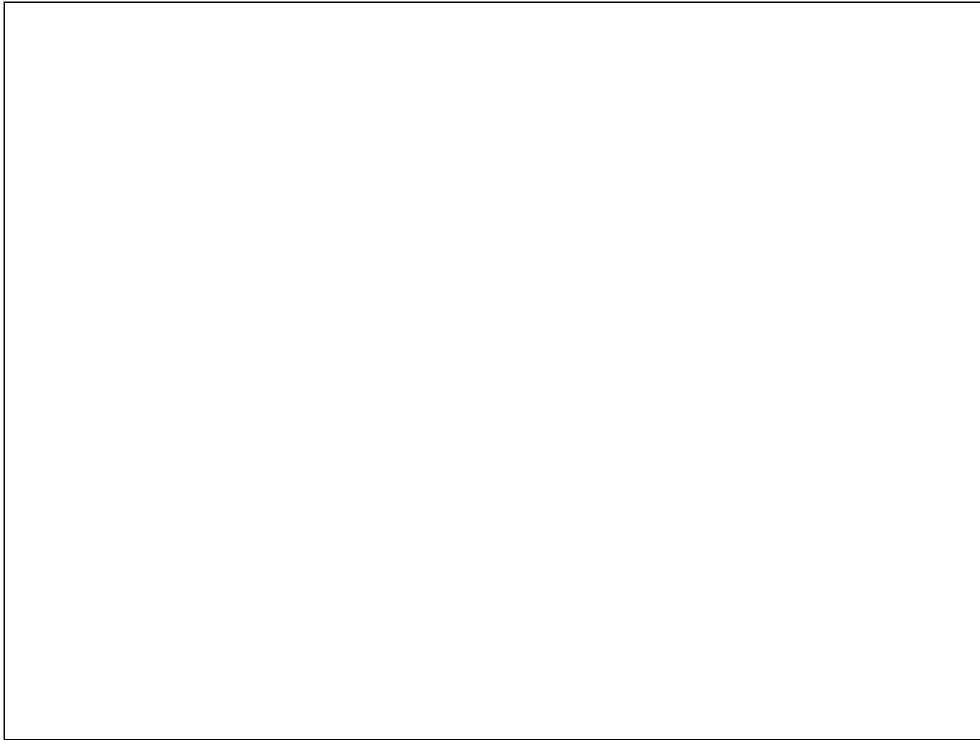

[Por00] J.W. Porter and J.A. Thweatt, "Microwave Propagation Characteristics in the MMDS Frequency Band", Proc. Int. Conf. On Commun., New Orleans, June, 2000.

[Sar95] H. Sari, G. Karam and I. Jeanclaude, "Transmission Techniques for Digital Terrestrial TV Broadcasting", IEEE Comm. Mag., Vol. 33, No. 2, Feb. 1995, pp. 100-109.

[Tar00] V. Tarokh and H. Jafarkhani, "On the Computation and Reduction of the Peak-to-Average Ratio in Multicarrier Communications", IEEE Trans. Commun., Vol. 48, No. 1, Jan., 2000, p. 37-44.

[Van00] C. van den Bos, M.H.L. Kouwenhoven and W.A. Serdijn, "The Influence of Nonlinear Distortion on OFDM Bit Error Rate", Proc. Int. Conf. On Commun., New Orleans, June, 2000.